

旋风页轮、铜孔磨片、牙科抛光套装、盘刷、丝轮、碗刷、笔刷
Radial Bristle Disc, Brass Center Abrasive Disc, Dental Polishing Set,
Dish Brush, Wheel Brush, Cup Brush, End Brush



ABOUT US

东莞略高研磨材料有限公司成立于2002年，专业从事各种研磨材料的研发和生产。

主要品种有旋风页轮、铜孔磨片、牙科抛光套装、盘刷、丝轮、碗刷、笔刷等。

适用领域广泛：金属制品的打磨、抛光、去刀纹、除锈等；牙科材料（修复体）的研磨、抛光等；主要面对手机配件、电脑配件、汽车配件、通用零部件以及牙科行业的表面处理。

我们注重每一个细节，严格控制产品的制造过程。通过原材料的选择和严格的质量管控，确保使用高质量的材料和可靠的工艺来生产磨料磨具；积极采纳用户的反馈和需求，不断改进和优化产品设计，以提供更好的用户体验。

我们的目标是为客户提供高质量的磨料磨具，帮助客户在工业加工中实现高效、精密的加工效果。我们也深知产品质量对客户生产力和成本控制的重要性，因此我们始终致力于提供性能稳定、耐用可靠的产品。

公司成立至今，我们在扩大工厂规模的同时也不断提高产品的质量，不断引进先进的生产设备和技术，我们将继续努力，以满足客户日益增加的需求。我们一直关注市场的变化和技术的进步，以保持市场竞争力，为客户提供最好的产品和服务。

欢迎国内外朋友提供课题，共同探讨，共同发展。

Deburking Abrasive Material CO.,LIMITED. was established in 2002, specializing in the development and production of various grinding materials.

The main varieties are radial bristle disc, brass center abrasive disc, dental polishing set, dish brush, end brush, wheel brush, cup brush and so on.

A wide range of applications: grinding, polishing, cutting, rust removal of metal products; Dental materials (prosthetics) grinding, polishing, etc.; It mainly faces the surface treatment of mobile phone accessories, computer accessories, auto parts, general parts and dental industry.

We pay attention to every detail and strictly control the manufacturing process of our products. Through the selection of raw materials and strict quality control, to ensure the use of high-quality materials and reliable processes to produce abrasives; Actively adopt user feedback and needs, and constantly improve and optimize product design to provide a better user experience.

Our goal is to provide customers with high-quality abrasives to help customers achieve efficient and precise machining results in industrial processing. We also understand the importance of product quality to our customers' productivity and cost control, which is why we are always committed to providing stable performance, durable and reliable products.

Since its establishment, we have continuously improved the quality of products while expanding the scale of the factory, and constantly introduced advanced production equipment and technology. We will continue to work hard to meet the increasing needs of customers. We always pay attention to the changes in the market and the progress of technology in order to maintain market competitiveness and provide customers with the best products and services.

Welcome friends at home and abroad to provide topics, discuss together, and develop together.

互利双赢 共享快乐

我们坚持诚信经营的理念，互利互助，实现双赢

Mutual benefit and win-win sharing happiness

We adhere to the concept of integrity management, mutual benefit and mutual assistance to achieve a win-win situation



应用领域与产品

Application Areas and Products

3C电子领域
3C Electronics



旋风页轮
Radial Bristle Disc



盘刷
Disc Brush



笔刷
End Brush



研磨丝轮
Wheel Brush



碗刷
Cup Brush

五金领域
Hardware

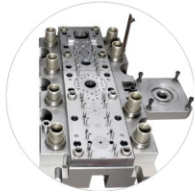

旋风页轮
Radial Bristle Disc



盘刷
Disc Brush



笔刷
End Brush



研磨丝轮
Wheel Brush



碗刷
Cup Brush

辊轴领域
Roller fields



旋风页轮
Radial Bristle Disc



盘刷
Disc Brush



笔刷
End Brush



研磨丝轮
Wheel Brush



碗刷
Cup Brush

卫浴领域
Bathroom



旋风页轮
Radial Bristle Disc



盘刷
Disc Brush



笔刷
End Brush



研磨丝轮
Wheel Brush



碗刷
Cup Brush

汽车领域
Automotive



旋风页轮
Radial Bristle Disc



盘刷
Disc Brush



笔刷
End Brush



研磨丝轮
Wheel Brush



碗刷
Cup Brush

造船领域
Shipbuilding



旋风页轮
Radial Bristle Disc



盘刷
Disc Brush



笔刷
End Brush



研磨丝轮
Wheel Brush



碗刷
Cup Brush

航空航天领域
Aerospace field



旋风页轮
Radial Bristle Disc



盘刷
Disc Brush



笔刷
End Brush



研磨丝轮
Wheel Brush



碗刷
Cup Brush

牙科领域
Dental field



牙科自轴
抛光碟套装
Dental Polishing Set



铜扣磨片
Brass Center
Abrasive Disc



技术
Technology



品质优良
Excellent quality



意向创造
Intention creation



服务
Service

目录 CONTENTS

旋风页轮 Radial Bristle Disc	01
铜扣磨片 Brass Center Abrasive Disc	09
牙科自釉抛光碟套装 Dental Polishing Set	12
盘刷 Disc Brush	14
笔刷 End Brush	17
研磨丝轮 Wheel Brush	20
碗刷 Cup Brush	22

旋风页轮

Radial Bristle Disc



产品简介

旋风页轮出色的薄片设计，能深入结构复杂的缝隙或凹槽部位发挥功效，更适合圆弧或拐角部位的打磨处理。而且能自主组合需求的厚度，机动灵活。不仅适配普通的电动或气动工具，也特别适合自动化生产线和设备的配置。

使用专用的陶瓷磨粒和模制的柔性刷毛，使用寿命期间保持研磨性能。可去除大面积的油漆、污渍、粘合剂、焊缝烧伤、锈蚀、重氧化物和表面污染物。可轻松处理各种复杂工件，快速高效去除毛刺，达到理想的表面效果。其中，旋风页轮适用于半导体行业特定规格，产品不含硅油。

尺寸齐全，粒度齐全，刷毛盘规格有D15mm, D20mm, D33, 1", 1.5", 2", 3", 4", 6", 8"; 另外3", 4", 6", 8"还有直丝规格，可以配合用定向配给设备。我们有50#、80#、120#、220#、320#、400#、600#、1000#、2500#、5000#粒度以满足不同的要求。

Radial bristle disc excellent chip design, can penetrate into the complex structure of the gap or groove to play a role, more suitable for round arc or corner sanding treatment. It is also flexible in terms of the combination of thicknesses required. It is suitable not only for ordinary electric or pneumatic tools, but also for automated production lines and equipment.

The use of proprietary ceramic abrasive grains and molded flexible bristles maintains abrasive performance over the life of the machine. Removes large areas of paint, stains, adhesives, weld burns, rust, heavy oxides and surface contaminants. Easily handles a wide range of complex workpieces, removing burrs quickly and efficiently to achieve the desired surface finish. Among them, the cyclone page wheel is suitable for specific specifications of the semiconductor industry, and the product does not contain silicone oil.

Complete size, complete particle size, bristle disk specifications are D15mm, D20mm, D33, 1", 1.5", 2", 3", 4", 6", 8"; In addition 3", 4", 6", 8" also straight wire specifications, can be used with Directiona distribution equipment. We have 50#、80#、120#、220#、320#、400#、600#、1000#、2500#、5000# grain to meet different requirements.

色卡请参考以下粒度

Please refer to the granularity for color cards



50#
Green



80#
Yellow



120#
White



220#
Red



320#
Brown



400#
Light blue



600#
Purple



1000#
Light green



2500#
Creamy white



5000#
Greyish white

RBD15



Size: D15mm
Rmp max: 20000
Packaging: 200Pcs/bag

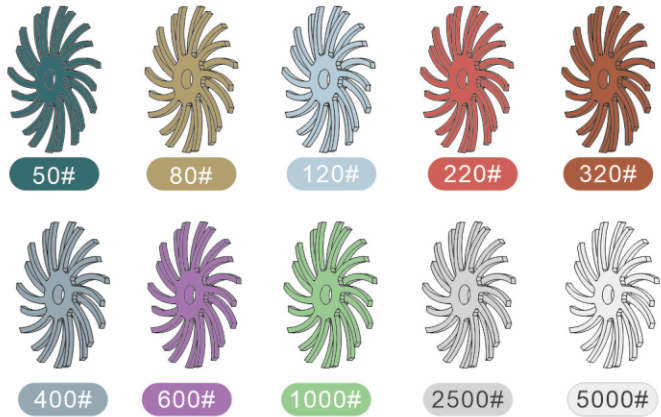
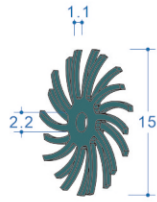

RBD20



Size: D20mm
Rmp max: 20000 RPM
Packaging: 200Pcs/bag

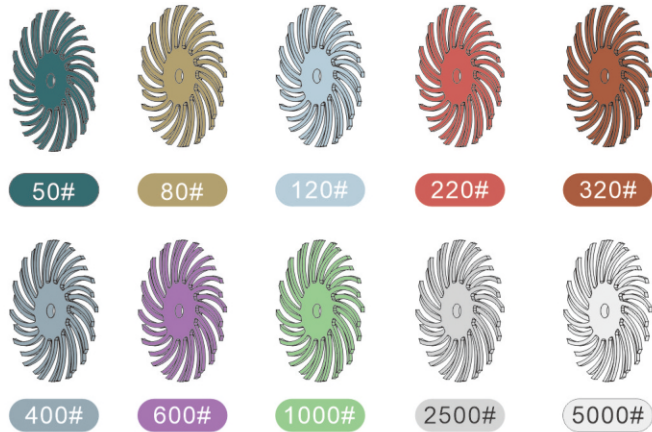
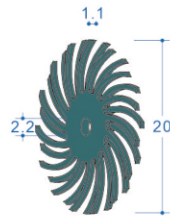

RBD25



Size: 1inch
Rmp max: 20000 RPM
Packaging: 200Pcs/bag

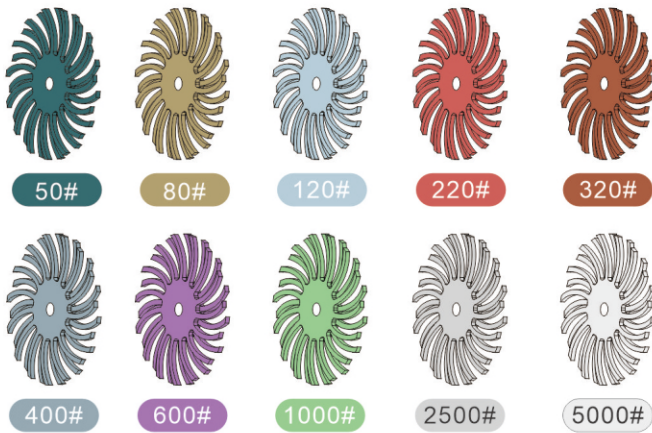
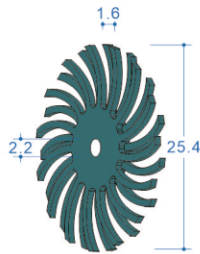

RBD33-1



Size: D33mm
Rmp max: 15000 RPM
Packaging: 100Pcs/bag

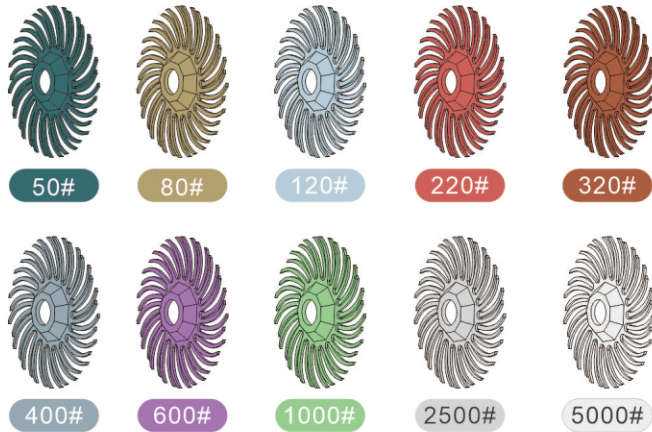
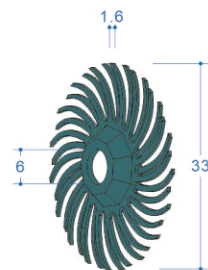

RBD33-2



Size: D33mm
Rmp max: 15000
Packaging: 100Pcs/bag

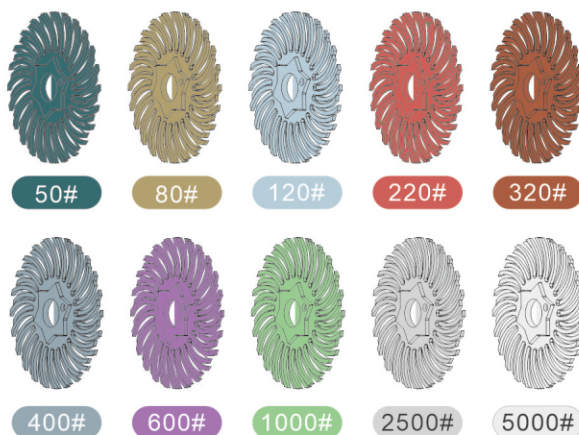
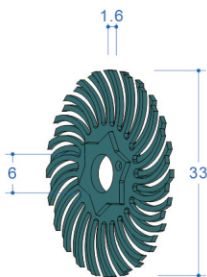

RBD38



Size: 1.5inch
Rmp max: 15000
Packaging: 100Pcs/bag

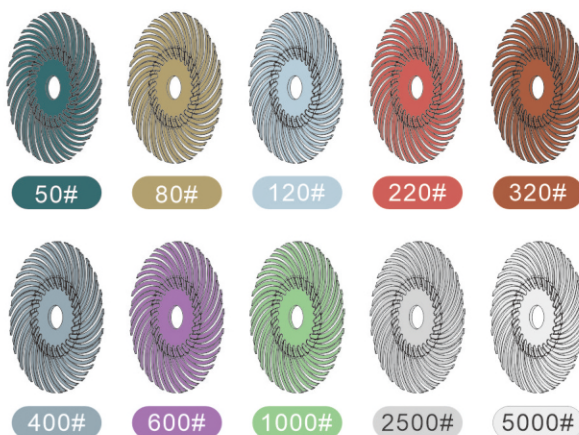
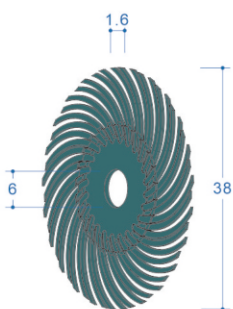

RBD50



Size: 2inch
Rmp max: 10000
Packaging: 50Pcs/box
1000pcs/Carton

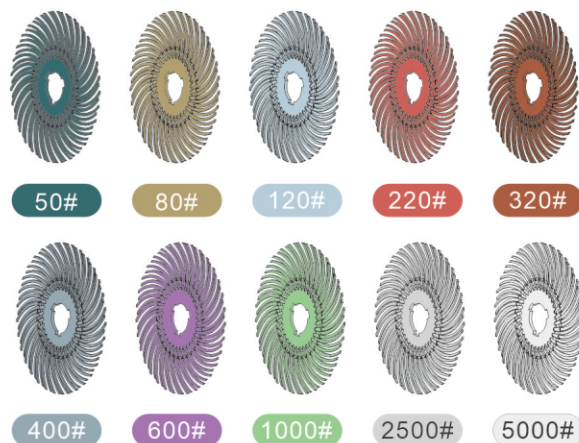
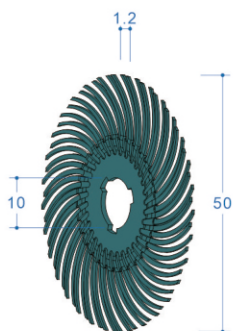

RBD76



Size: 3inch
Rmp max: 10000
Packaging: 50Pcs/box
1000pcs/Carton

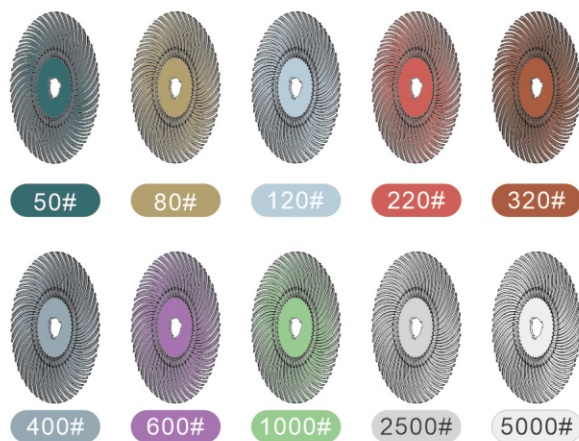
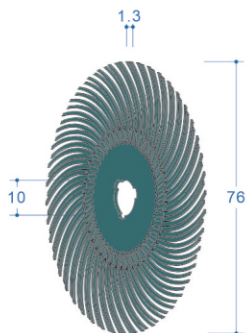

RBD76A



Size: 3inch
 Rmp max: 10000
 Packaging: 50Pcs/box
 1000pcs/Carton

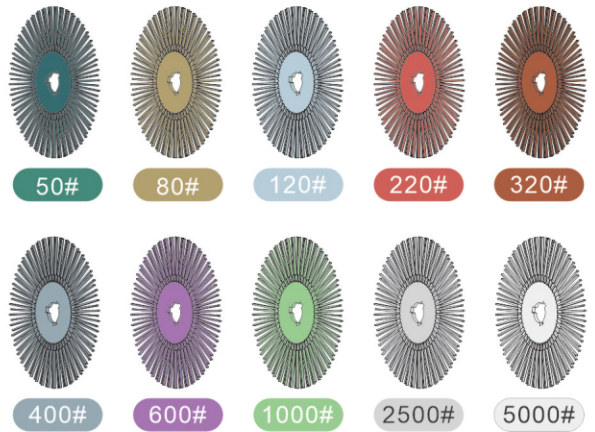
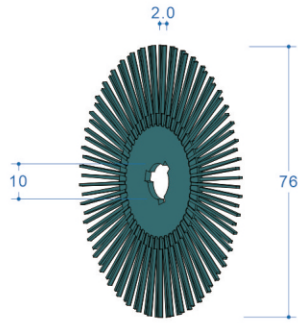

RBD96



Size: 4inch
 Rmp max: 6000
 Packaging: 50Pcs/box
 1000pcs/Carton

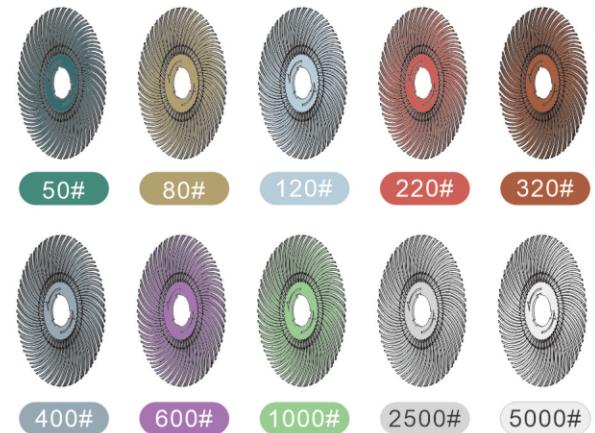
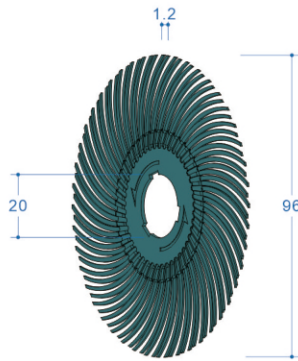

RBD96A



Size: 4inch
 Rmp max: 6000
 Packaging: 50Pcs/box
 1000pcs/Carton

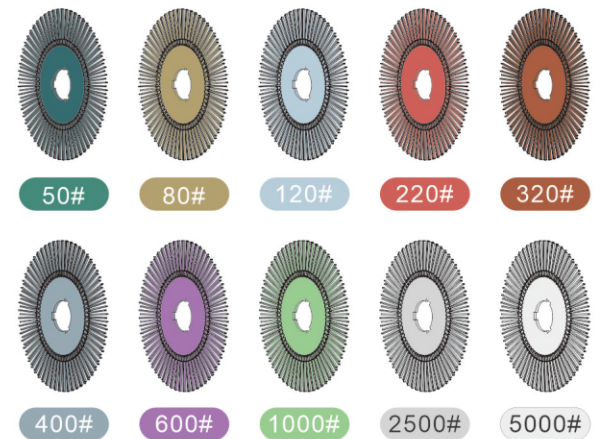
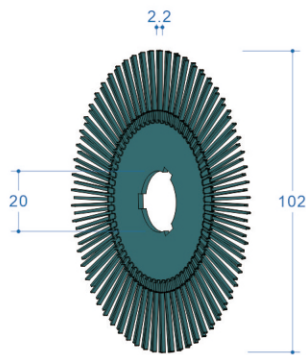

RBD150

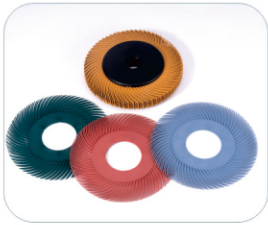

Size: 6inch
 Rmp max: 5000
 Packaging: 50Pcs/box
 400pcs/Carton

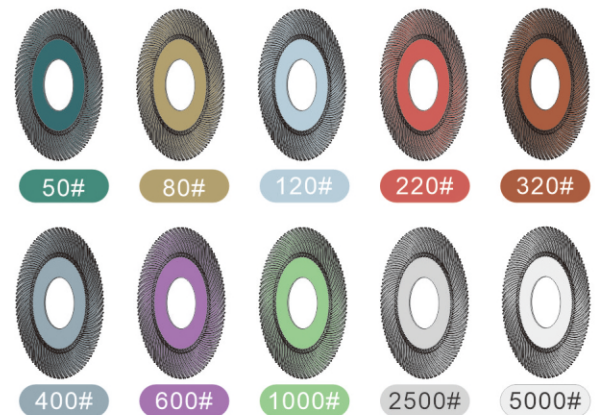
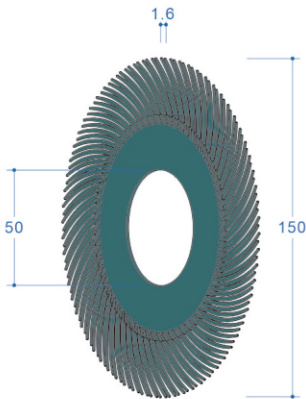

RBD150A



Size: 6inch
Rmp max: 5000
Packaging: 50Pcs/box
400pcs/Carton

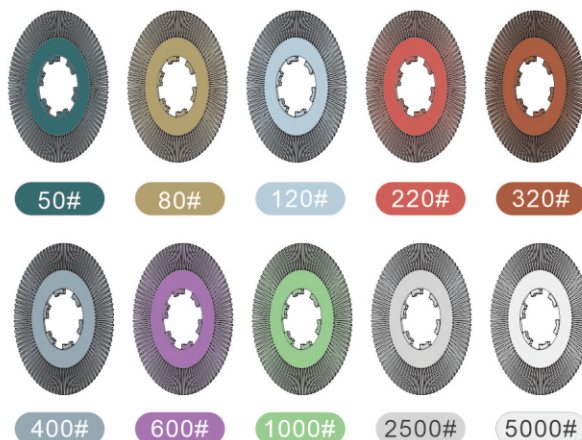
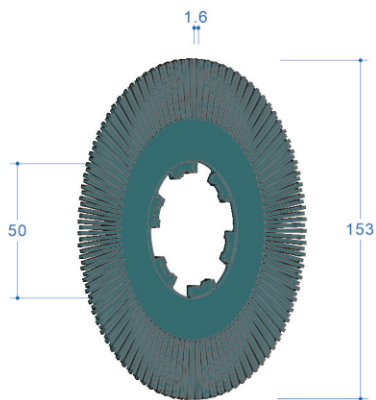

RBD150B



Size: 6inch
Rmp max: 5000
Packaging: 50Pcs/box
400pcs/Carton

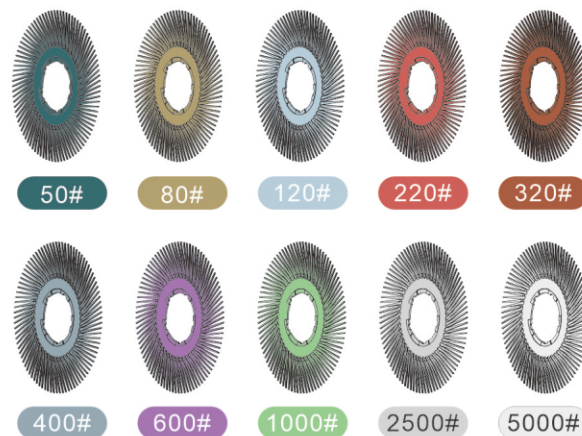
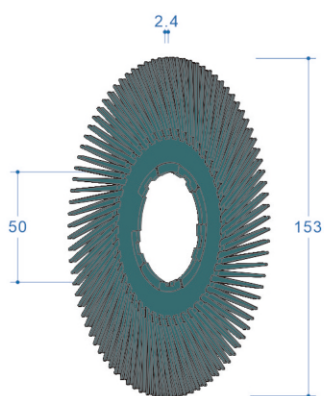

RBD203

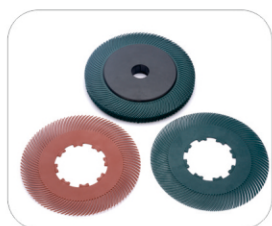

Size: 8inch
Rmp max: 4000
Packaging: 50Pcs/box
200pcs/Carton

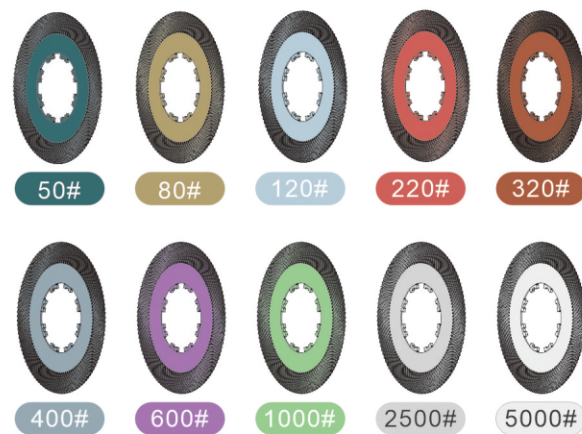
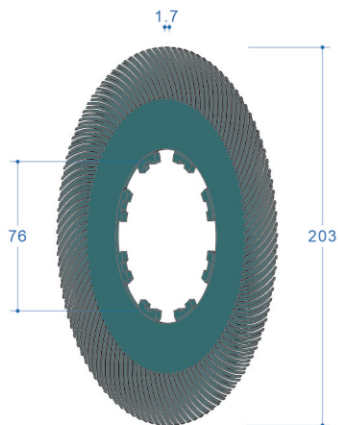

RBD203A

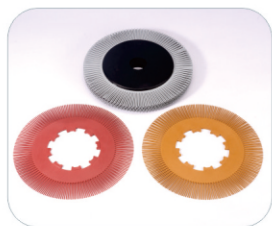

Size: 8inch
Rmp max: 4000
Packaging: 45Pcs/box
180pcs/Carton

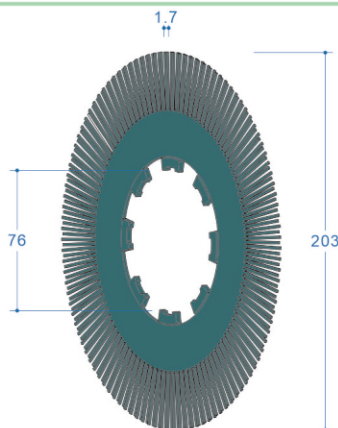

适用页轮: RBD15/20/25

FT S3

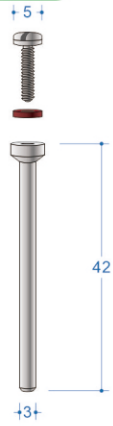
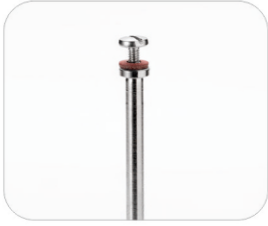

适用页轮: RBD33-1/2, RBD38

FT S6

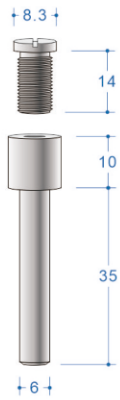

适用页轮: RBD50/76/76A

FT 5076

FT 5076S6S

FT 5076S6L

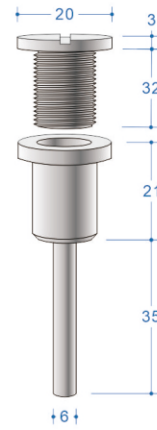
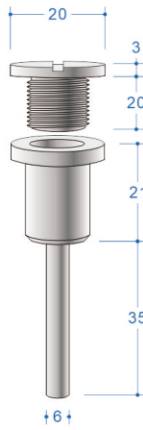
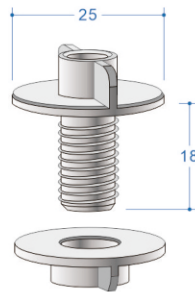

适用页轮: RBD96/96A

FT 96S6S

FT 96S6L

FT 96S8S

FT 96S8L

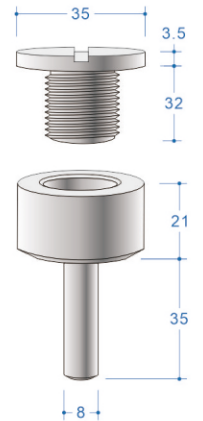
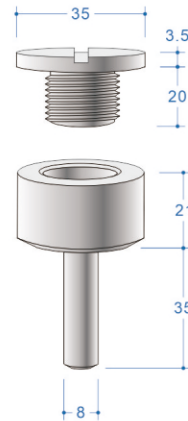
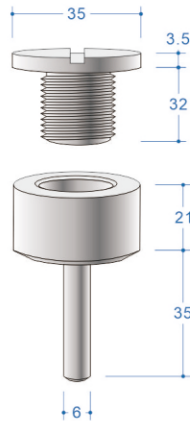
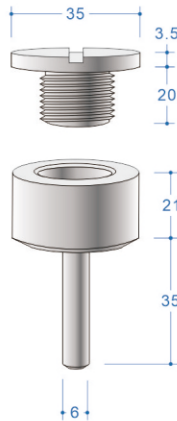

适用页轮: RBD150/150A

FT150-10

FT150-8

FT150-6

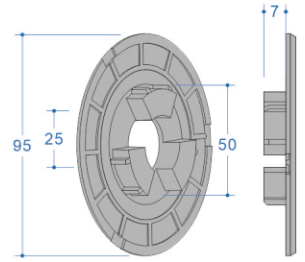
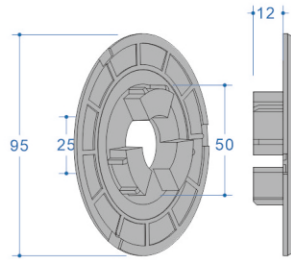
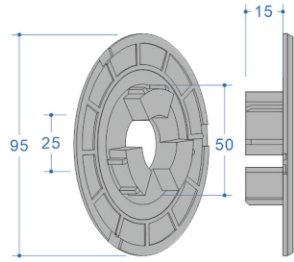

FT150-6/8/10

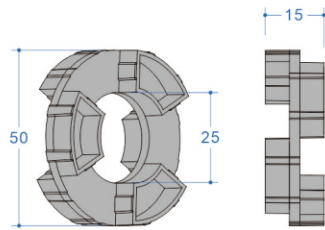

适用页轮: RBD203/203A

FT203

FT203-1

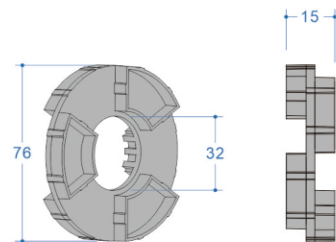
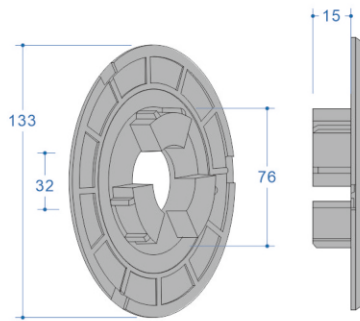
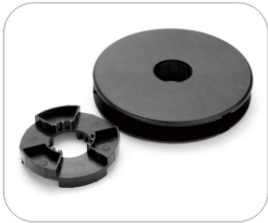

铜扣磨片

Brass Center Abrasive Disc



产品简介

7/8"快拆四方铜扣磨片，砂纸材料有氧化铝、3M塑胶。适用于抛光首饰中常用的金、银等软金属。它分为粗、中和精三种粒度，中间是方形的铜片安装孔，需要配合直角心轴一起使用。心轴由不锈钢制成，除了方便安装外，还可以减少研磨盘的振动，建议最高转速20,000转。请使用前佩戴护目镜等保护措施。

7/8 inch Garnet discs with brass center, At present, we have two types of materials, alumina and 3M plastic, Suitable for polishing soft metals such as gold and silver commonly used in jewelry. It is divided into three particle sizes: coarse, medium, and fine, with a square copper mounting hole in the middle that needs to be used together with a right angle spindle. The spindle is made of stainless steel, which not only facilitates square installation, but also reduces the vibration of the grinding disc. Suggest a maximum speed of 20000 rpm, with one box of 50 pieces and a large box of 600 pieces. Please wear protective measures such as goggles before use.

SZ22-1

150#

220#

320#

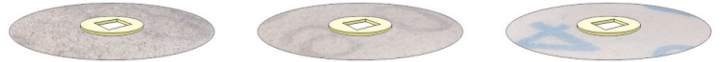

Rmp max: 20000
Packaging: 100 pcs/bag

SZ22-2

150#

240#

400#



Rmp max: 20000
Packaging: 100 pcs/bag

SZ22-3

240#

320#

600#

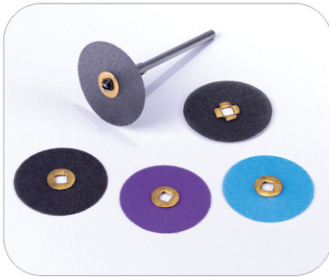

Rmp max: 20000
Packaging: 100 pcs/bag

SZ22-4

80#

120#

320#

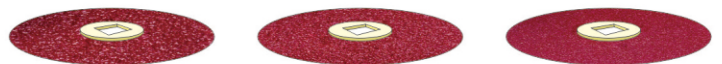

Rmp max: 20000
Packaging: 100 pcs/bag

牙科自釉抛光碟套装

Dental Polishing Set



产品简介

牙科自釉抛光碟套装用于硬质树脂和复合树脂的修整、烤瓷、氧化锆清洁和抛光。

共3种颜色，分为240#(粗) 600#(中) 3000#(细)，一盒包含6片牙科抛光盘，方便牙科使用，带有透明塑料盒，便于存放。

含金刚石等磨料的高分子树脂，主要用于牙科材料使用放射状刷毛盘获得快速而优异的效果！其独特的磨料/柔性刷毛设计提供了均匀的光洁度。用于重度清洁、火垢和轻度氧化物去除，以及预抛光、半精加工、混合、纹理和抛光。圆盘提供了预装磨料的便利性，而不会产生与橡胶轮相关的热量。

Dental polishing set used for repairing hard resin and composite resin, cleaning and polishing porcelain and zirconia.

There are three colors in total, divided into 240 # (coarse), 600 # (medium), and 3000 # (fine). Each box contains six dental polishing discs for convenient dental use, and comes with a transparent plastic box for easy storage

Polymer resin containing abrasives such as diamonds, mainly used in dental materials to achieve fast and excellent results using radial bristle discs! Its unique abrasive/flexible bristle design provides a uniform finish. Used for heavy cleaning, removal of scale and mild oxides, as well as pre polishing, semi finishing, mixing, texturing, and polishing. The disc provides the convenience of pre loading abrasives without generating heat related to rubber wheels.

TR01

1st

2nd

3rd



Composite polishing KIT
RMP max: 20000

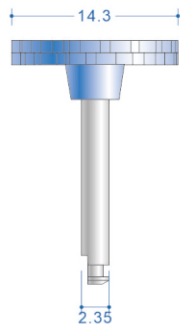

TR02

1st

2nd

3rd



Zirconia grinding and
polishing KIT
RMP max: 20000

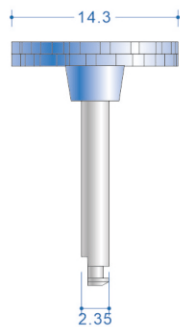

盘刷

Disc Brush



产品简介

盘刷可大面积去除毛刺，同时提供理想的表面光洁度。薄膜的形状也可以修改：点、块或弧。圆盘刷是定制设计机器或 CNC 的理想选择。可湿磨和干磨。湿磨效果更佳，中央进水或侧面进水，底部中心出水，打磨同时冲刷粉末污渍，不产生粉尘，没有燃爆的危险。特别适用于汽车零部件、发动机缸体、液压件、气动件等的去毛刺打磨处理。可以按客户要求设计制造。

The Disc brush removes burrs from large areas while providing an ideal surface finish. The shape of the film can also be modified: point, block or arc. Disc brushes are ideal for custom-designed machines or CNCs. Wet and dry grinding is available. Wet sanding is more effective, with water in the center or on the sides, water out of the bottom center, sanding and flushing powder stains at the same time, without generating dust and without the risk of ignition. It is especially suitable for deburring and sanding automobile parts, engine blocks, hydraulic parts, pneumatic parts and so on. It can be designed and manufactured according to customers' requirements.

Dia: 145mm



RMP max: 2000

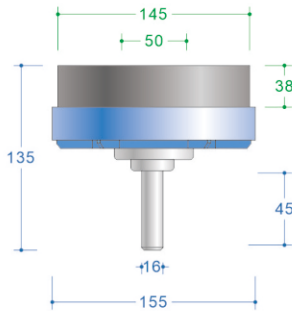

DBZ145
柱形

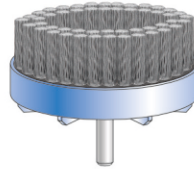

DBD145
等份

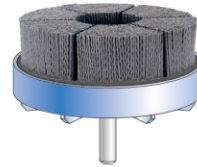

DBF145
弧形

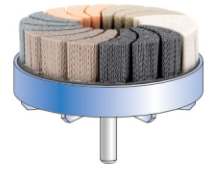

Dia: 120mm



RMP max: 2000

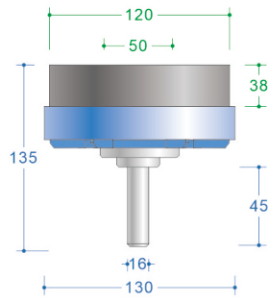

DBZ120
柱形

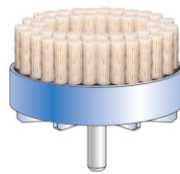

DBD120
等份

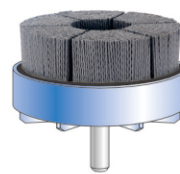

DBF120
弧形



Dia: 100mm

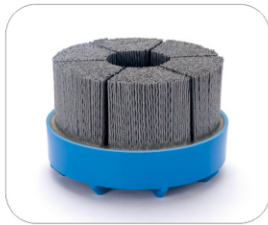

RMP max: 2000

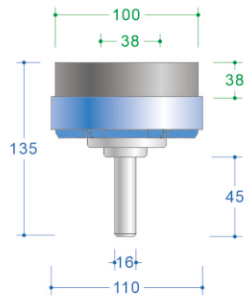

DBZ100
柱形

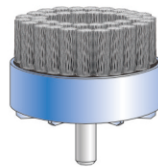

DBD100
等份

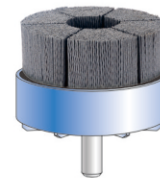

DBF100
弧形



Dia: 80mm



RMP max: 2500

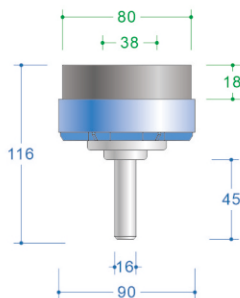

DBZ80
柱形

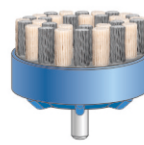

DBD80
等份

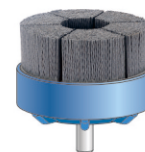

DBF80
弧形



Dia: 60mm

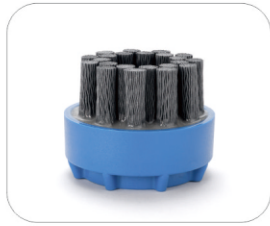

RMP max: 2500

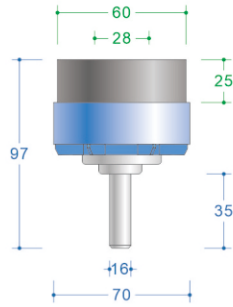

DBZ60

柱形

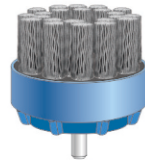

DBD60

等份

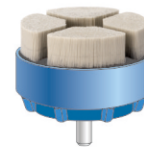

DBF60

弧形



Dia: 55mm



RMP max: 2500

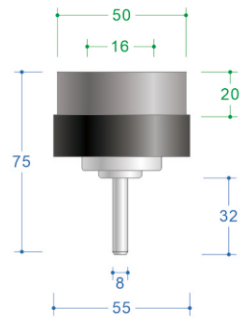

DBZ55

柱形



DBD55

等份



Dia: 45mm



RMP max: 2500

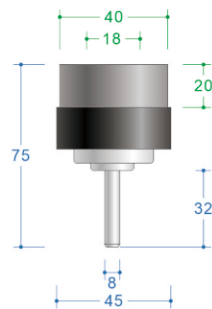

DBZ45

柱形



DBD45

等份



Dia: 35mm



RMP max: 2500

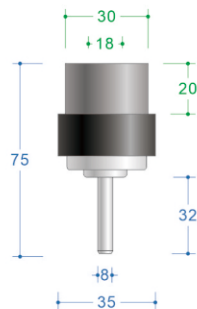

DBZ35

柱形



笔刷 End Brush

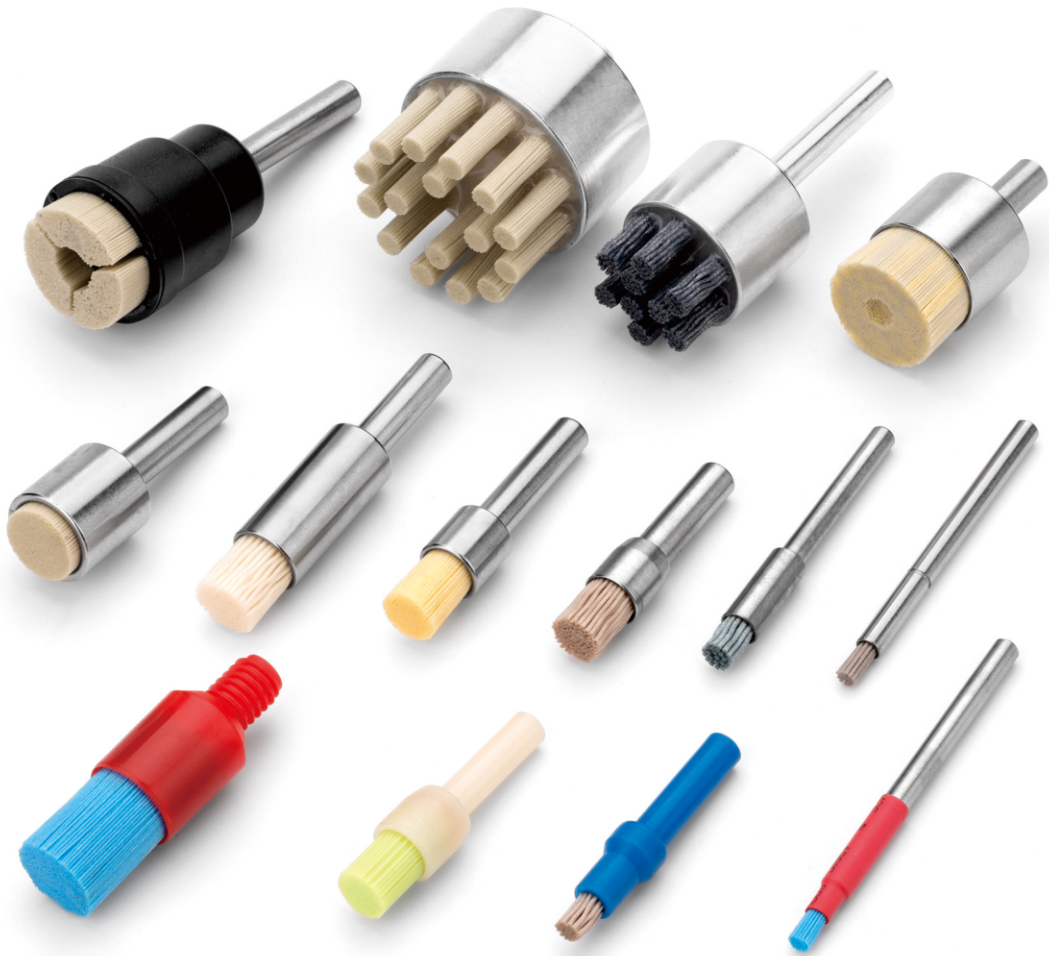

产品简介

笔刷主要用于表面进行去毛刺和精细抛光，在零件加工时，可以弯曲并自然贴合零件轮廓并进入其他一般工具无法进入的槽孔，去除毛刺、污渍、油漆和锐边并钝化成光滑的圆弧，最终达到去毛刺、磨边和表面光洁度的理想效果。精加工效果好、质量高、使用寿命长、高性能、高安全性。可与自动化机械配套使用。电子行业、金属行业、彩钢板、钢瓦、冶金、珠宝、汽车等领域应用广泛。我们还可以根据客户要求提供定制服务。

End Brushes are mainly used for surface for deburring and fine polishing, in parts processing, can be bent and naturally fit the contour of the parts and enter other general tools can not enter the groove holes, remove burrs, stains, paint and sharp edges and obtuse into smooth arc, and ultimately to achieve the ideal effect of deburring, edge grinding and surface finish. Good finishing effect, high quality, long service life, high performance and high safety. Can be used with automated machinery. Widely used in electronics industry, metal industry, color steel plate, steel tile, metallurgy, jewelry, automotive and other fields. Customer design requirements can be produced

F001

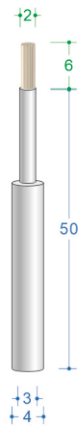

EB S4D2T6
RMP max 6000

A079

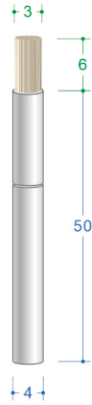

EB S4D3T6
RMP max 6000

A097

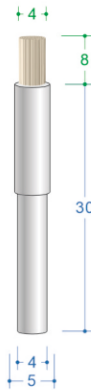

EB S4D4T8
RMP max 6000

A075

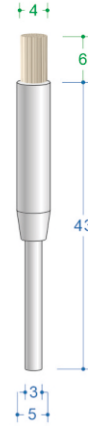

EB S3D4T6
RMP max 6000

A013-B

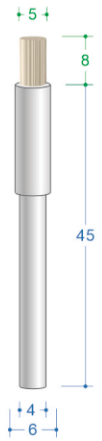

EB S4D5T8
RMP max 6000

A013

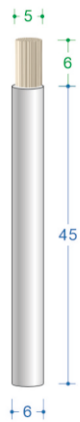

EB S6D5T6
RMP max 6000

A073B

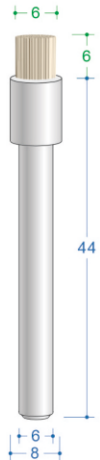

EB S6D6T6
6000 RPM

A073

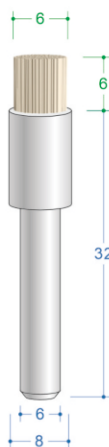

EB S6D6T6
RMP max 6000

A016B

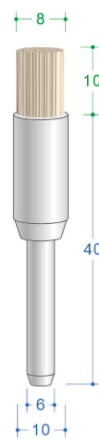

EB S6D8T10
RMP max 6000

A064

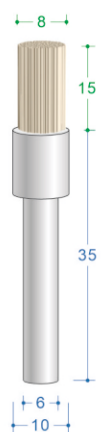

EB S6D8T15
RMP max 6000

A003

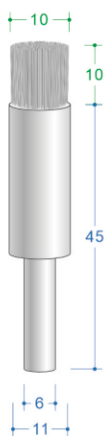

EB S6D10T10
RMP max 4500

D15

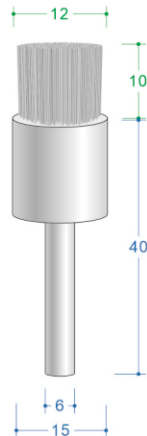

EB S6D12T10
RMP max 4500

D16

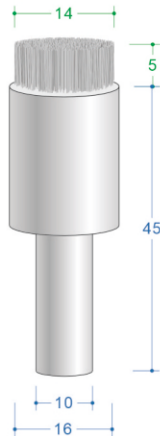

EB S10D14T5
RMP max 4500

A95

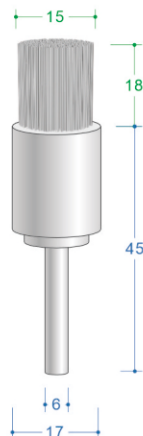

EB S6D15T18
RMP max 4500

D20

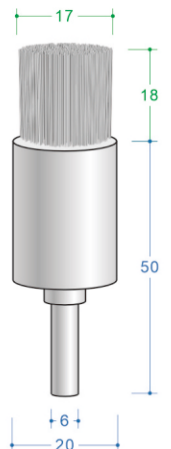

EB S6D17T18
RMP max 4500

A93

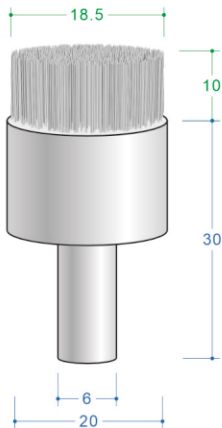

EB S6D18.5T10
RMP max 4500

D24

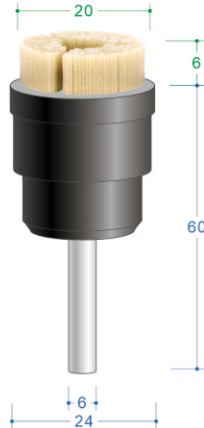

EB S6D20T6F3
RMP max 4500

D23



EB S6D20T10
RMP max 4500

D23



EB S6D20T10Z9
RMP max 4500

D35

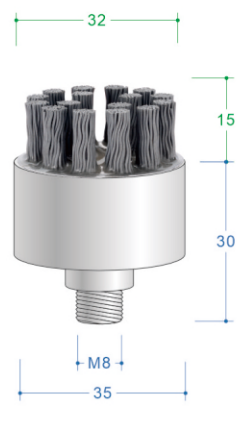

EB M8D32T15Z16
RMP max 4500

A007

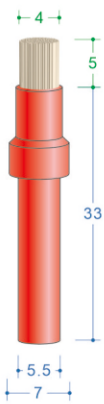

EB S5.5D4T5
RMP max 6000

A009

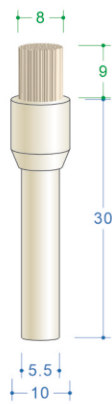

EB S5.5D8T9
RMP max 6000

OPM808

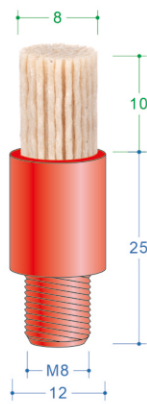

EB M8D8T10
RMP max 6000

OPM810

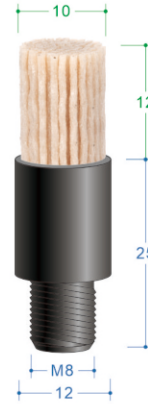

EB M8D10T12
RMP max 6000

OPM812.5

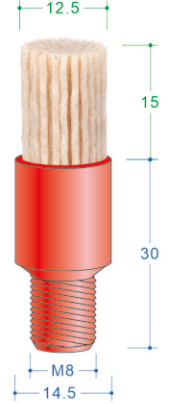

EB M8D12.5T15
RMP max 6000

研磨丝轮

Wheel Brush



产品简介

研磨丝轮有带柄、不带柄。方便与手持电动工具、CNC、机械手配合使用。

轮刷是机械零件加工后去除毛刺最合适的工具。可安装在砂磨机、角磨机、气动工具上进行毛刺去除。

轮刷钻头附件在清洁、去除锈迹和油漆、平滑、清洁铸接缝的毛刺、轻微去毛刺时提供更轻的刷牙动作和出色的光洁度。它们非常适合清洁抛光和抛光接头/焊接接头或角落和难以到达的区域。标准的 6 毫米轴附件使其易于与任何手钻一起使用。我们还可以根据客户要求提供定制服务。

Grinding wheels are available with and without shanks. Convenient to use with handheld power tools, CNC, robots.

Wheel brushes are the most suitable tool for deburring mechanical parts after machining. Can be mounted on sanders, angle grinders, and pneumatic tools for deburring.

Wheel Brush Drill Attachments provide lighter brushing action and excellent finish when cleaning, removing rust and paint, smoothing, cleaning burrs from cast joints, and light deburring. They are perfect for cleaning polishing and buffing joints/welded fittings or corners and hard to reach areas. The standard 6mm shaft attachment makes them easy to use with any hand drill. Customer design requirements can be produced

WH150

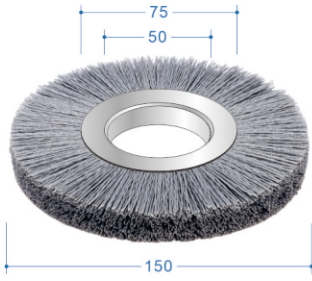

RMP max 4500

WH100

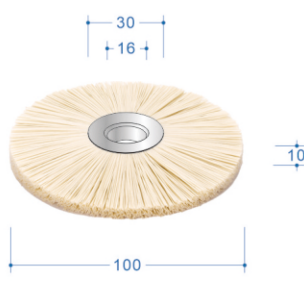

RMP max 4500

WH65

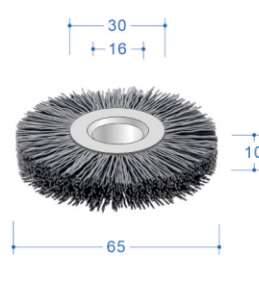

RMP max 6000

GWH130

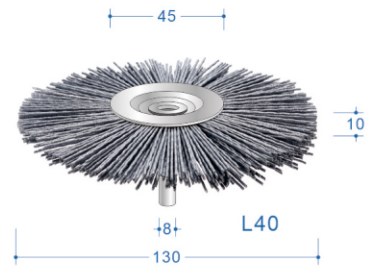

RMP max 4500

GWH75 01



RMP max 5000

GWH75



RMP max 5000

GWH55



RMP max 6000

GWH50



RMP max 6000

GWH35



RMP max 6000

GWH35 01

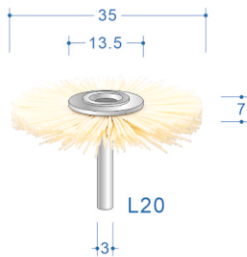

RMP max 6000

GWH30



RMP max 6000

GWH30 01



RMP max 6000

碗刷

Cup Brush



产品简介

碗刷应用于工件的内腔，有较复杂的台阶，凸起部的金属件去毛刺毛边的加工，特别适用于笔记本，平板电脑和手机内框的去毛刺，打磨，整理的工序，孔边的毛刺去除。适配机械手或CNC使用，可以按客户的订要求设计制造。

Cup brush is applied to the inner cavity of the workpiece, with more complicated steps and the processing of deburring and burring edges of the metal parts in the raised part, especially suitable for deburring, polishing and finishing processes of the inner frame of notebook, tablet computer and mobile phone. Burr removal at hole edge. Suitable for manipulator or CNC. Can be designed and manufactured according to customer requirements.

CB65



RMP max 6000

MCB65



RMP max 6000

CB40



RMP max 6000

CB25



RMP max 4500

CB16



RMP max 4500

NCB48



RMP max 4500



东莞略高研磨材料有限公司

Deburking Abrasive Material CO.,LIMITED

Office: Unit 'B' on 9/F Thomson Commercial Building 8 Thomson Road Hong Kong
 Factory: Room 101, Building 2, No. 1 Caotang road, Nancheng street, Dongguan city, Guangdong Province, China
 E-mail: deburking@deburking.com kl.luo@deburking.com
 Phone: +86-18676938733 +86-13829116202
 Tel: +86-0769-22984368
<https://www.deburtool.com>



www.deburtool.com



WhatsApp



WeChat